

# Usable Kitchens



When designing a kitchen for use by persons with mobility impairments, especially those who use wheelchairs, careful layout of the kitchen is crucial to maintaining accessibility. People who are mobility impaired may:

- have walking and standing limitations which require them to sit while working
- use a mobility aid such as crutches, canes, or walkers
- use a wheelchair.

One of the key issues to consider when designing for persons with mobility impairments is adequate space to maneuver a mobility aid such as a wheelchair or walker. The pages that follow provide information based upon ANSI and UFAS standards for designing an accessible kitchen.

# Base Cabinet with Self-storing Folding Doors and Floor

A second type of adaptable base cabinet uses self-storing retractable door hardware and a hinged floor to expose the knee space (Figure 12). The self-storing features permit the cabinet to be adapted without the necessity of storing the removed base cabinet in another location.

To expose the knee space, the doors swing open and slide back along the sides of the cabinet into a stored position. The cabinet floor folds up against the back wall to expose the finished floor below (Figures 13,14, and 15).

This cabinet works well with the fixed 34-inch maximum height counter that ANSI and UF AS allow. It also works with an adjustable height counter by adding shims or a drawer unit to raise the height of the counter (see Figure 18). While building this type of cabinet may be somewhat more expensive than modifying a standard base cabinet, the self-storing design may be preferred where storage space is unavailable.

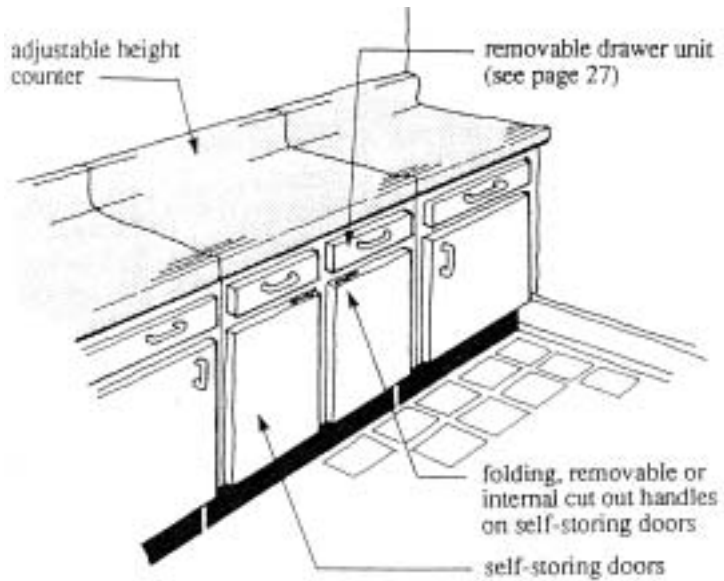


Figure 12.  
Adaptable Base Cabinet with Self-storing Doors

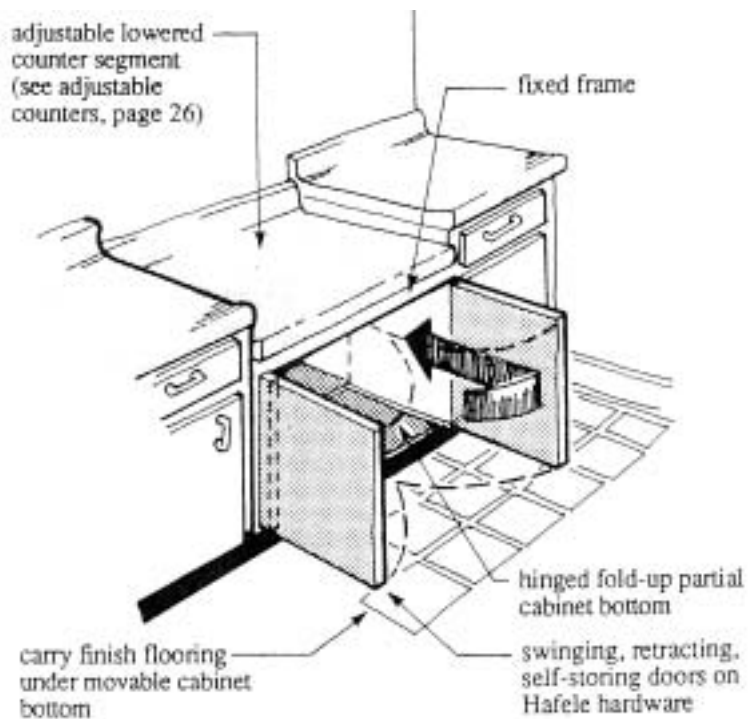
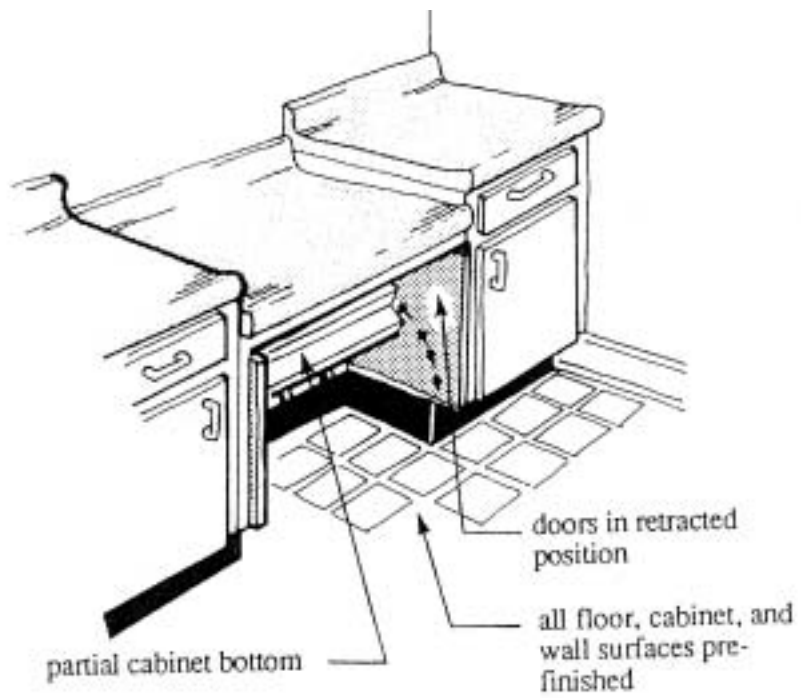
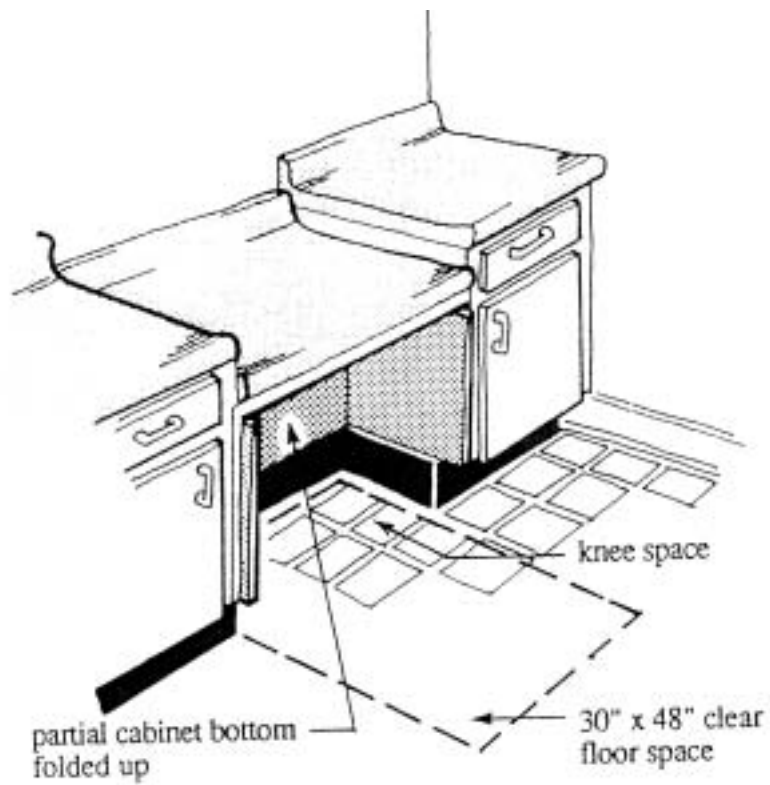


Figure 13.  
Storing Doors to Expose the Knee Space



*Figure 14.*  
Adapting Self-storing Cabinet Floor



*Figure 15.*  
Self-storing Cabinet with Exposed  
Knee Space

# Removable Cabinet Floor and Front

In another type of adaptable base, the cabinet uses a removable cabinet and floor inserted between two other fixed base cabinets to provide storage and conceal the knee space. Builders can construct this unit from a standard sink or range front panel attached to a base.

It has two operable cabinet doors with two fixed, false drawer fronts above (Figure 16). The floor extends the full depth of the adjacent cabinets, providing a large storage space after installing the unit in the knee space. Builders install the front panel and the floor as a unit so that can be unfastened from the adjacent cabinets by removing screws along the sides. The adjacent cabinets should be equipped with threaded metal inserts that will withstand repeated installation and removal. The whole unit slides forward to expose the knee space (Figure 17). The front and floor can be stored as a unit or taken apart and stored flat. Any of the adjustable counter support methods described in the following section, are usable with this removable cabinet front and floor.

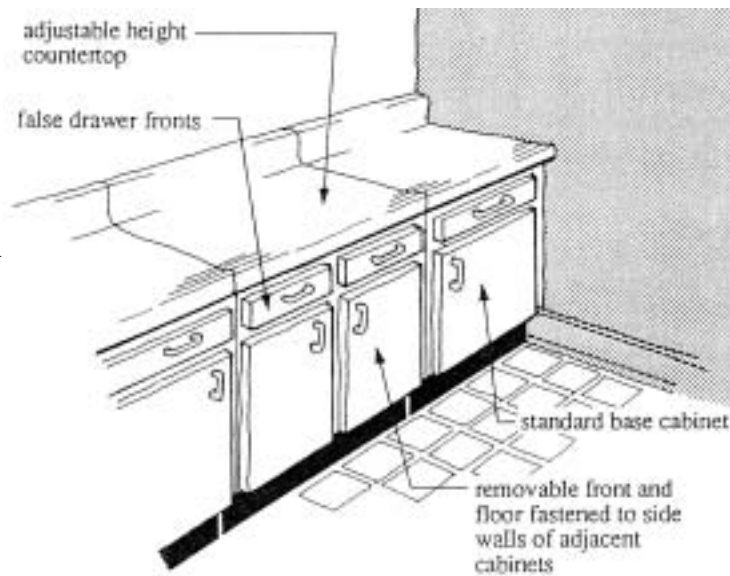


Figure 16.  
Removable Cabinet Front and Floor

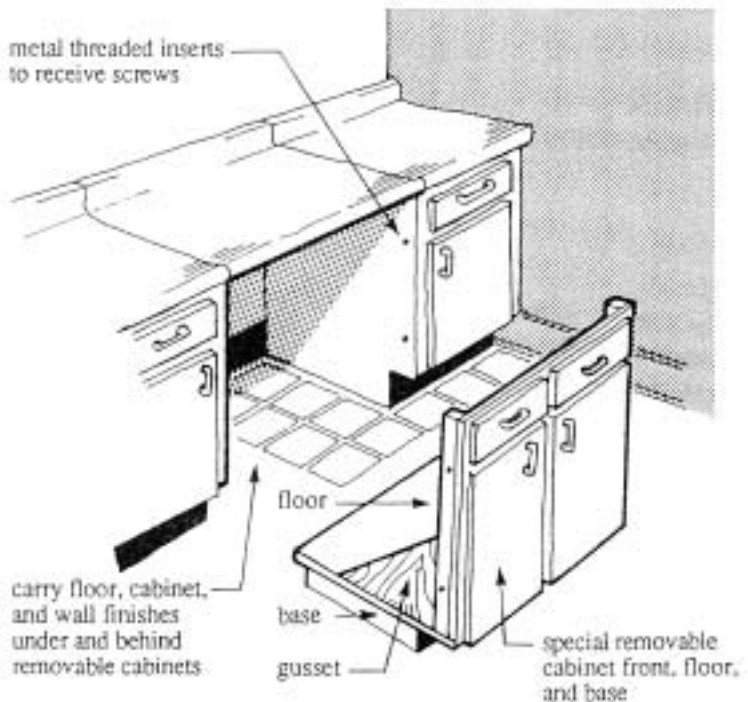


Figure 17.  
Removing Cabinet Front and Floor to Expose Knee Space

# Three Methods for Providing Adjustable Counters

Counter segments that are lowered or adjustable in height placed over knee spaces to make lowered or adjustable work surfaces, sinks, or cooktops. The lowered counter permits a seated person to pull up perpendicular to the front edge of the counter with his/her legs extending into the knee space, and reach the rear of the counter. The following three methods for providing adjustable height counter segments are simple, inexpensive, and use only common materials or readily available hardware. These methods are equally successful for work surfaces, sinks, or cooktops.

For all three methods, firmly attach the counter to the supporting device after adjusting the height so that it provides a stable surface. This is very important because people will lean on the counters, and might become injured if the counters are not secure. These are not mandatory methods but only suggestions intended to show some possible solutions for adjustable counters that meet the standards.

## Movable Wood Support Strips

The first method uses movable wood strips screwed into the sides of the adjoining base cabinets to provide support for the adjustable counter segment. The wood strips must be able to be set at a minimum of three pre-determined counter heights of 28 inches, 32 inches, and 36 inches. Builders can add other heights as long as these three are available.

Builders can attach the two wood strips to the cabinets with screws fastened into threaded metal inserts placed in the cabinet wall. The inserts provide long-term strength and stability and allow necessary repositioning of the counter to make it easier to adjust the counter height.

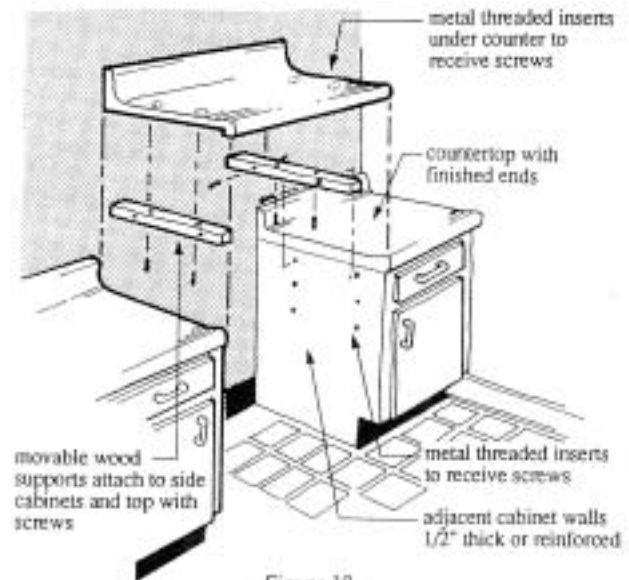


Figure 18.  
Movable Wood Support Strips for Adjusting Counter Height

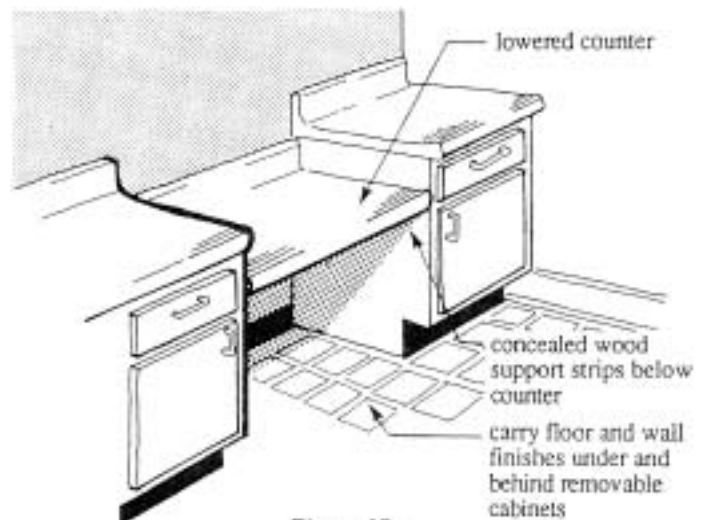


Figure 19.  
Lowered Counter Attached to Movable Wood Support Strips

To lower a counter supported with wood strips, first remove the counter by removing the screws that fasten it to the strips. With the strips exposed, remove the screws that hold the strip to the side cabinet, lower both strips to the desired height, and fasten the strips to the cabinet at the new height (Figure 18). After attaching both strips, install the counter on the strips with the original mounting screws (Figure 19).

The use of side strips is only one example of mounting an adjustable height counter to the sides of adjacent base cabinets. Builders can substitute metal angle brackets or a variety of conventional shelf support hardware for the supporting wood strips. Regardless of the type of support hardware used, secure the counter to prevent movement or tipping should the user pull, lift, or lean on the counter.

**Fixed Support Frame and Spacers**  
The second method uses a fixed support frame and spacers to vary the height of the counter (Figure 20). Builders can fasten the removal counter to the top of the fixed support frame or the top of the drawer units or spacers. The fixed frame supports the counter directly when installing the counter at the lowest height (Figure 21). When the counter height is increased, inserting spacers and/or drawer units of various thicknesses raises the counter to any height up to 36 inches.

Since the frame is not movable, this method may also provide a fixed lowered counter segment. Fixed segments 34 inches or lower are acceptable under ANSI

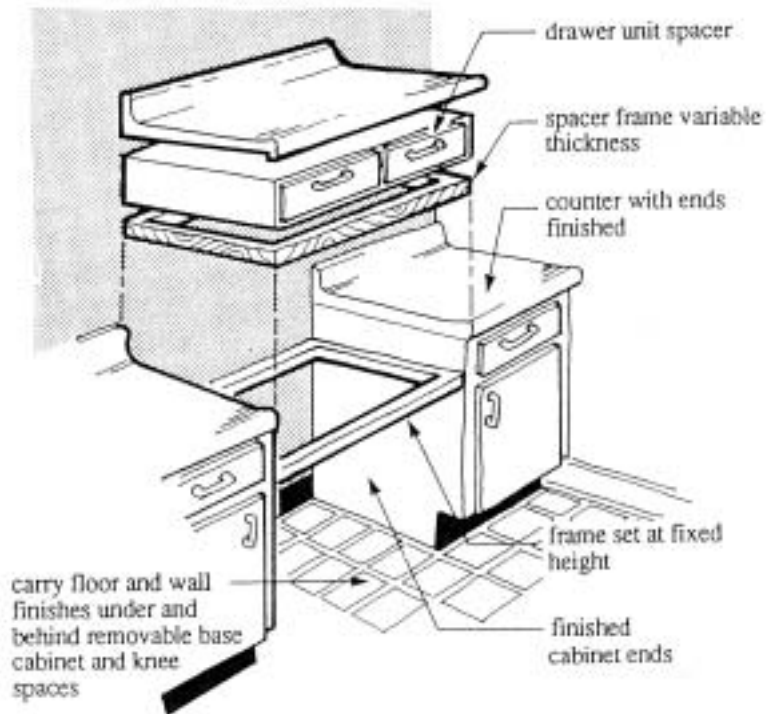


Figure 20.  
Fixed Frame and Variable Thickness Spacers

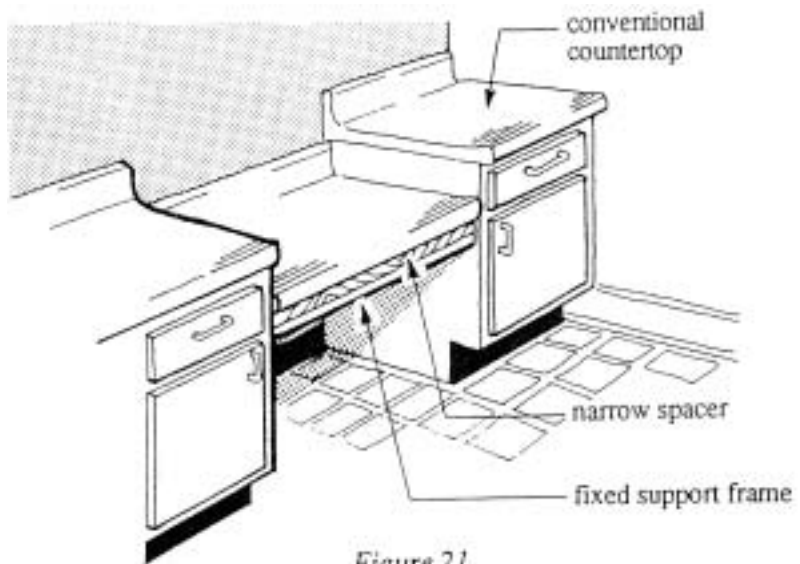


Figure 21.  
Lowered Counter on Fixed Frame

4.32.5.4 and UFAS 4.34.6.4. Note: This method may not meet clearance requirements of ANSI and UFAS for 2-inch maximum depth of counter at the knee space. Where compliance is critical, builders can make the fixed frame movable instead of installing inserts to raise the counter.

## Wall-Mounted Adjustable Brackets

Wall-mounted, large, heavy duty shelf brackets of the type commonly used for display counters in stores and commercial facilities can also be used to support adjustable counter sections. As shown in Figure 22, builders can lock the brackets into a track system firmly mounted to either, the studs or to wall reinforcing. The track system permits installing the counter at heights from 28 to 36 inches above the floor.

To adjust the height of the counter, first set the brackets into the tracks at the desired height and lock them into place. Then place counter over the brackets and securely fasten it (Figure 23). Builders may paint the track system to match the wall color. The counter is finished on both ends so that when lowered the exposed edges will match the color of the remaining counter.

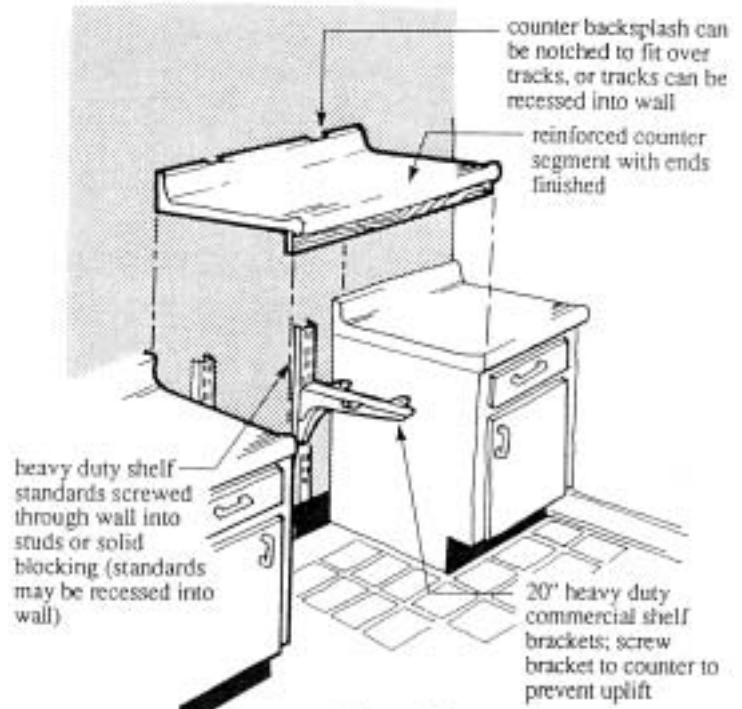


Figure 22.  
Wall-mounted, Adjustable Support Brackets

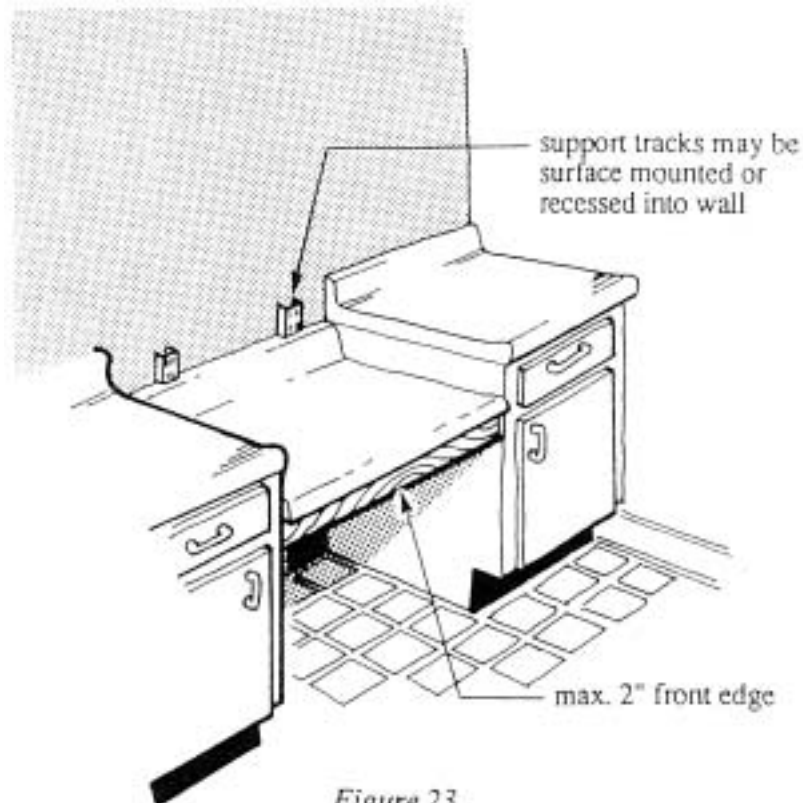


Figure 23.  
Lowered Counter on Wall-Mounted,  
Adjustable Support Brackets

## Applications of Adaptable Features in Kitchens

Adjustable height counters and their accompanying knee spaces can have several different applications in an adaptable kitchen. Besides using it for work surfaces, the lowered counter with knee space may be located next to a wall-mounted oven, a range, or a lowered cooktop, or used to provide an adjustable height sink.

### Work Surfaces

People who use wheelchairs and other people who must or wish to sit down while preparing food need at least one work surface lower than the usual 36-inch high counter (Figure 24).

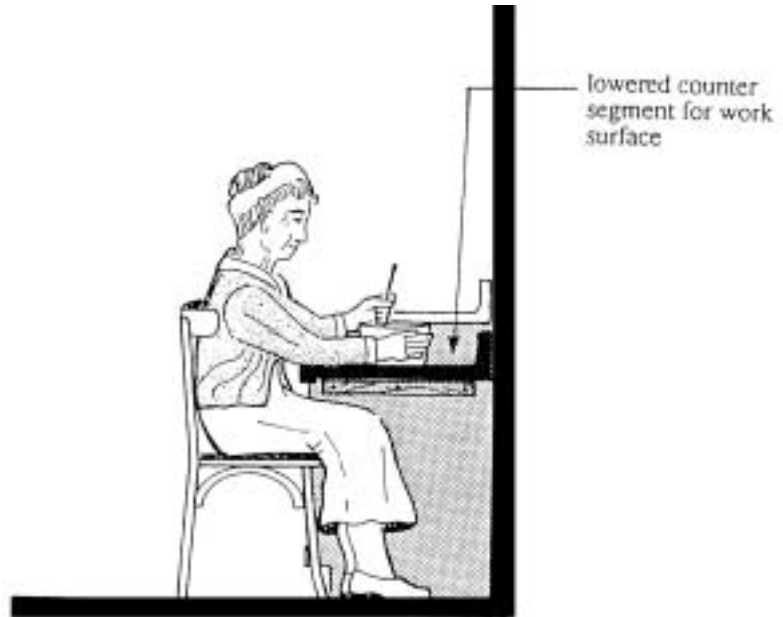


Figure 24.  
Seated Person at Lowered Work Surface

The standards (ANSI 4.32.5.4 and UFAS 4.34.6.4) require that at least one 30-inch wide, adjustable height work surface be provided in an adaptable kitchen although a wider size is preferred. The wider work surface provides space for pots, dishes, and other utensils, as well as, small appliances, and makes it easier to work on several things at once or to cook using many ingredients (Figure 25).

### Work Surfaces at Ovens

If installing a wall oven, also install a lowered work surface with knee space next to the wall oven. The standards specify that when the wall oven is not self-cleaning, a knee space must be located next to the oven to permit a disabled person in a wheelchair to pull up close enough to clean the oven (Figures 26 and 27).

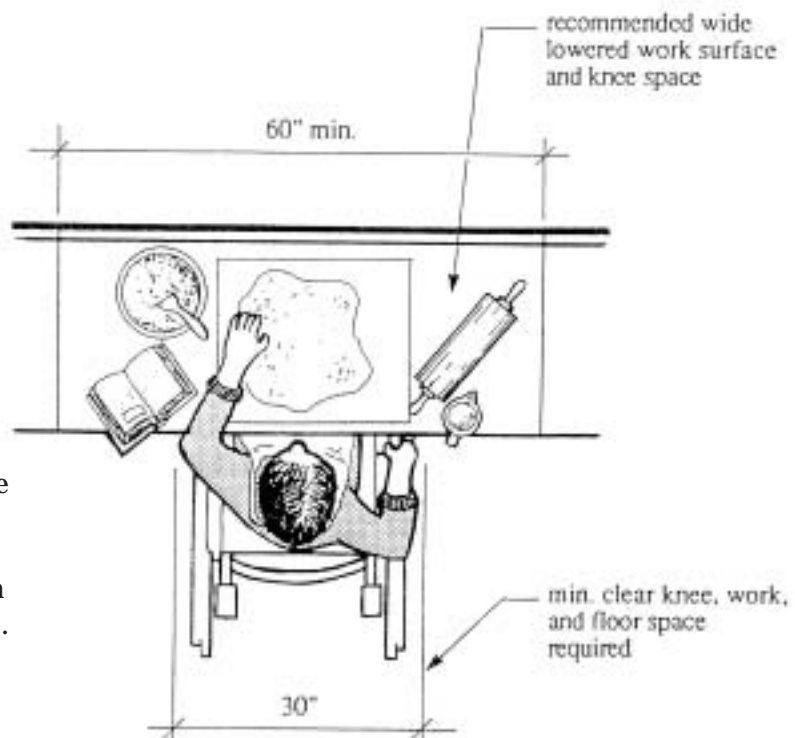
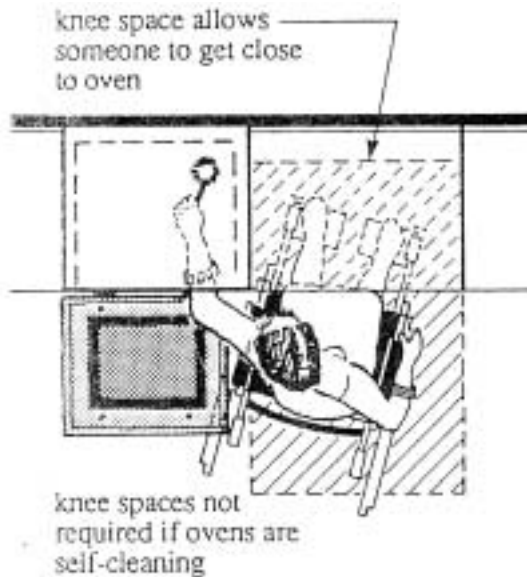


Figure 25.  
Use of a Wider, Lowered Work Surface



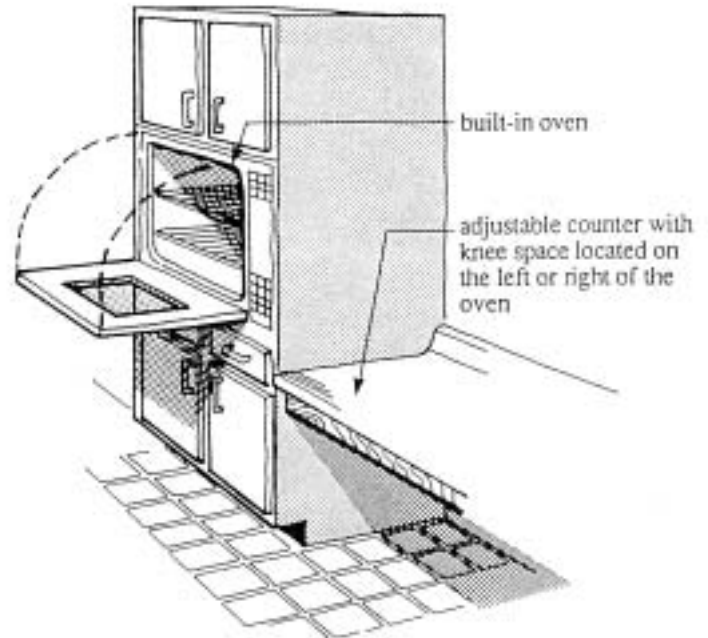
Even if installing a self-cleaning oven, locating the knee space next to the oven makes it easier and safer for a disabled person to remove hot items from the oven.

When an oven with a side-opening door is used, install a pull out shelf beneath the oven. Cook may use the shelf as a transfer surface for dishes

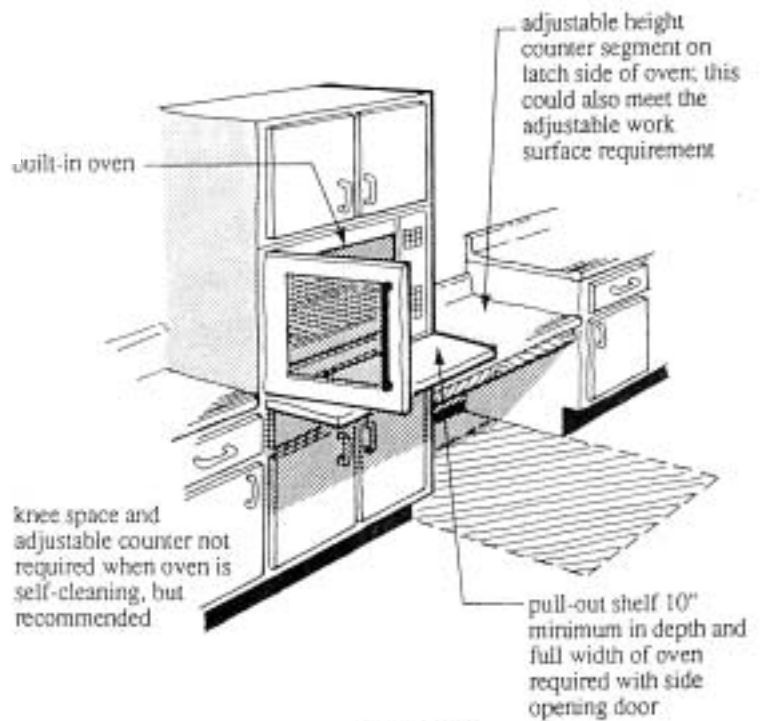


**Figure 27.**  
**Use of Knee Space Next to Oven**

placed into and removed from the oven. When not needed, cooks may push the shelf back into the oven cabinet (Figure 28). When an oven with a drop-front door is used (Figure 26), the pull out shelf is not necessary because the door serves as a transfer shelf. See ANSI 4.32.5.7 and UF AS 4.34.6.7 for dimensions and details of ovens.



**Figure 26.**  
**Work Surface at Non-self-cleaning Oven with Drop-front Door**



**Figure 28.**  
**Pull-out Shelf at Non-self-cleaning Oven with Side-opening Door**

# Cooktops in Adjustable Height Counter Segments

ANSI 4.32.5.6 and UFAS 4.34.6.6 permit use of a standard range if the controls comply with ANSI 4.25 or UFAS 4.27. Manufacturers must place the controls along the front or the side of the range so that a seated person need not reach across a hot burner to adjust the controls (Figure 29).

Some wheelchair users cannot use conventional ranges because the surface is too high and there is no knee space for maneuvering. Cooktops in lowered counter segments with knee space below allow some wheelchair users to get close enough to operate the controls and move heavy pots and pans (Figure 30).

Cooktops with smooth surfaces are preferred by people with limited hand and arm strength because they can slide pots of hot food on and off the cooktop rather than lifting them over raised burners and knobs.

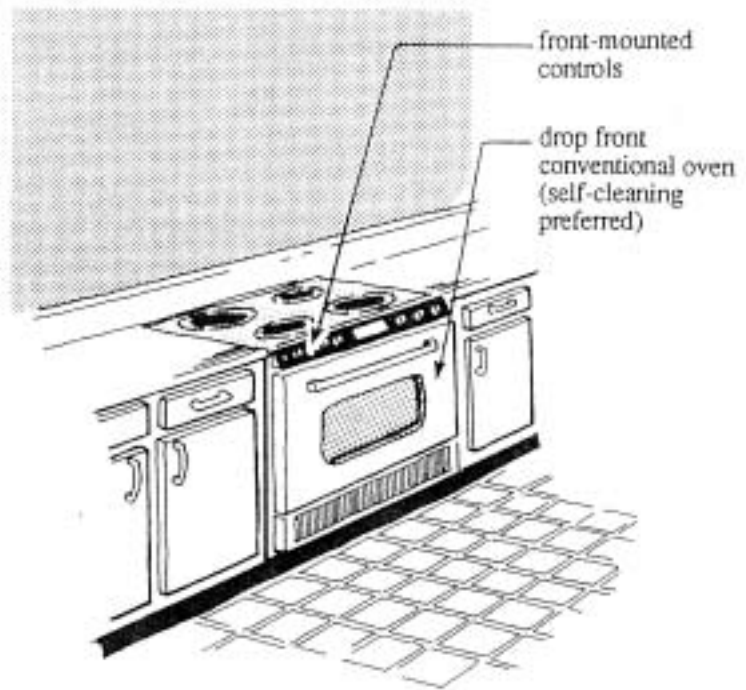


Figure 29.  
Standard Range

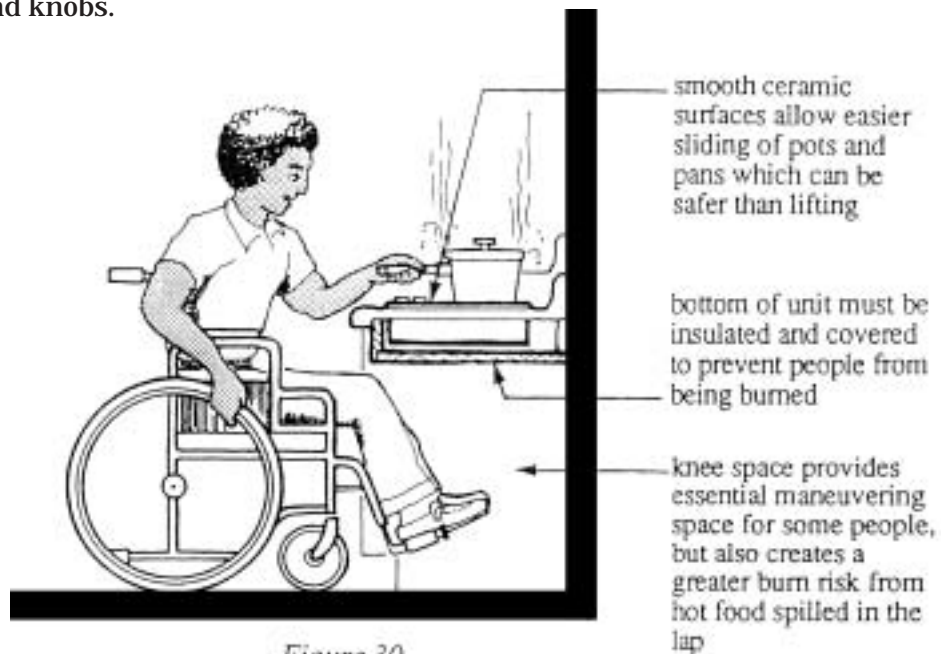


Figure 30.  
Use of Cooktop with Knee Space

When installing a cooktop into a lowered counter, the width of the counter segment and knee space should be at least 30-inches and should provide space to the side of the cooktop for utensils and maneuvering. An additional 30-inches to the side is recommended (Figure 31).

When the knee space is under a cooktop, the standards require an insulated cooktop bottom to protect against accidental burns.

While this type of installation may be the only way that some people can cook, it does expose a person in a wheelchair to the hazard of spilling hot food in his/her lap. People who pull up beneath the cooktop must exercise extreme care and cool hot foods before moving them.

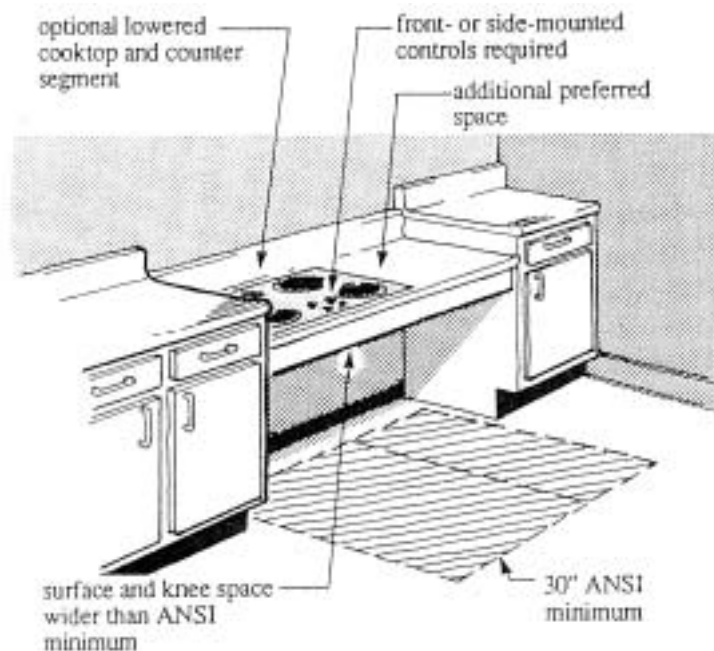


Figure 31.  
Lowered Cooktop with Knee Space and Wide Counter

## Sinks in Adjustable Height Counter Segments

Like lowered work surfaces, sinks mounted in lowered counters are required by the standards (ANSI 4.32.5.5 and UFAS 4.34.6.5). People who use wheelchairs, seated people, short people, and children have a hard time using a 36-inch high sink. The standards require provision of a sink in a lowered counter that is at least 30-inches wide and has a knee space (Figure 32).

Sinks must not be deeper than 6-1/2 inches. Single or double bowl sinks may be used. If a double bowl sink is used, only one of the bowls must not be deeper than 6-1/2 inches. Sinks with drains located near the back are also best because they keep pipes and disposals further back and out of the knee space clearances.

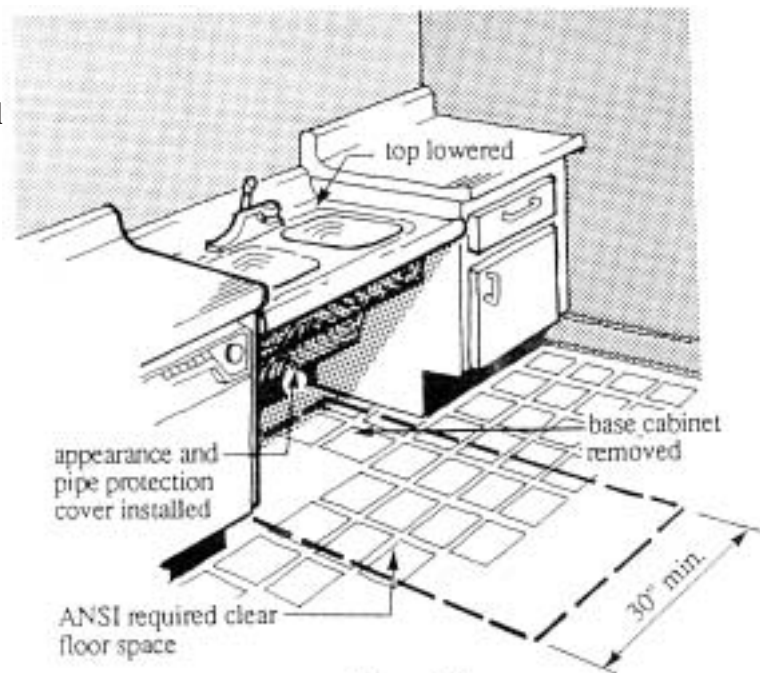


Figure 32.  
Sink in Minimum Width Adjustable Counter Segment

The minimum counter width specified by ANSI and UF AS is 30 inches. When sinks are installed in adjustable counter segments, a wider sink and counter combination is preferred to provide extra space at the sink level for dishes and utensils. The additional width permits a seated person to stack dirty dishes on the lowered counter before washing, and it eliminates lifting heavy pots and pans from the bottom of the sink (6-1/2 inches below the lowered counter) up to a 36-inch high counter, which some people cannot do safely (Figure 33).

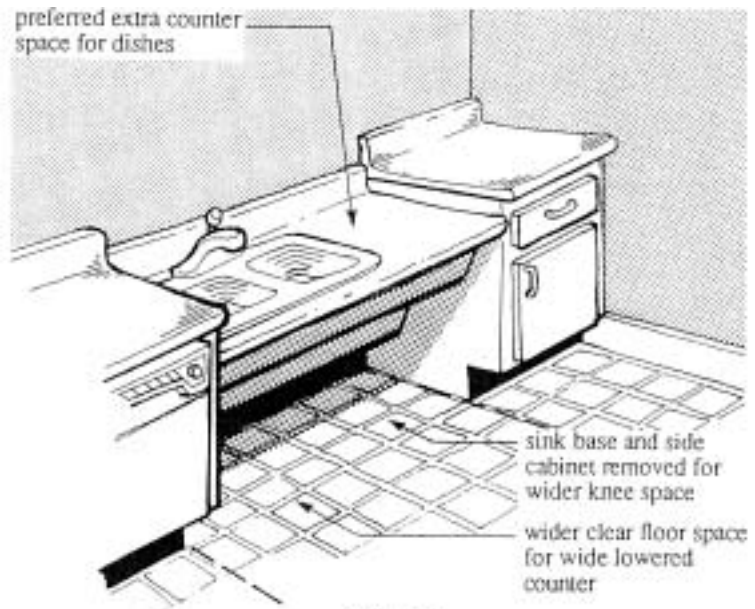


Figure 33.  
Sink in Preferred Wider Counter

## Pipe Protection at Lowered Sinks

Builders must design knee spaces under sinks so that people will not receive bumps or abrasions on their legs from contact with the hot water and drain pipes. Many people who use wheelchairs have limited sensation in their legs and cannot feel the heat when they are touching a hot pipe or even after a serious burn occurs.

The pipes can be wrapped with insulation, but each time the plumbing is serviced, the insulation must be removed and then re-installed which may result in the insulation being left off the plumbing. A better method is to install a removable panel over the plumbing. This panel shields the seated person from possible burns and hides the plumbing from view (Figure 34).

If a panel is used, install it so that the knee space is not limited and a seated person can pull up to the sink (see ANSI and UFAS for clearance dimensions). The panel also must be hinged or otherwise removable to permit easy servicing of pipes and adjustment of the counter height.

sinks with drains near back are best for knee space clearances

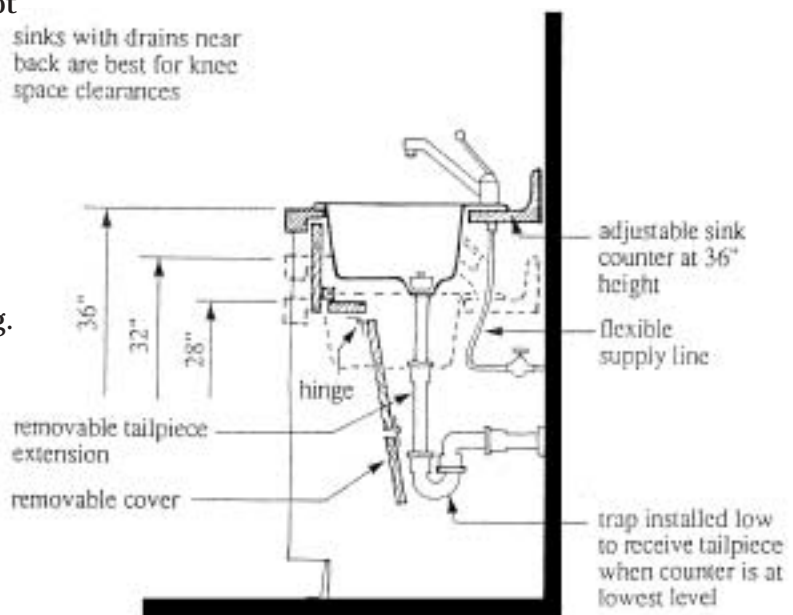


Figure 34.  
Section at Adjustable Sink with Base Cabinet Removed and Appearance and Pipe Protection Cover Installed

## Disposals Installed in Lowered Sinks

Many disabled and non-disabled people benefit from having a disposal in the kitchen. It makes cleanup much easier and reduces the amount of heavy garbage that must be first carried to the wastebasket and later to another waste receptacle outside the dwelling.

Installing disposals in lowered sinks is permissible, as long as the minimum 30-inch knee space width remains under the sink. Some disposals and sink assemblies will interfere with required knee space clearances under sinks and may not fit inside the protective cover shown in Figure 34.

Figures 35 and 36 show an alternative method of installation for disposals at lowered sinks. Figure 35 shows a second base cabinet removed so that the width of the lowered area is increased. Offsetting the sink places one bowl over the knee space and a second bowl over an enclosed section containing the disposal. A seated person can pull up under the right hand bowl, operate the lever handle faucet, and wash dishes or vegetables. From this position, an individual can scrape garbage into the other bowl and rinse into the disposal.

The standards do not require installation of a disposal, so long as the builder provides other required features: lowered sink, knee space, insulation, lever handle faucet, and clear floor space.

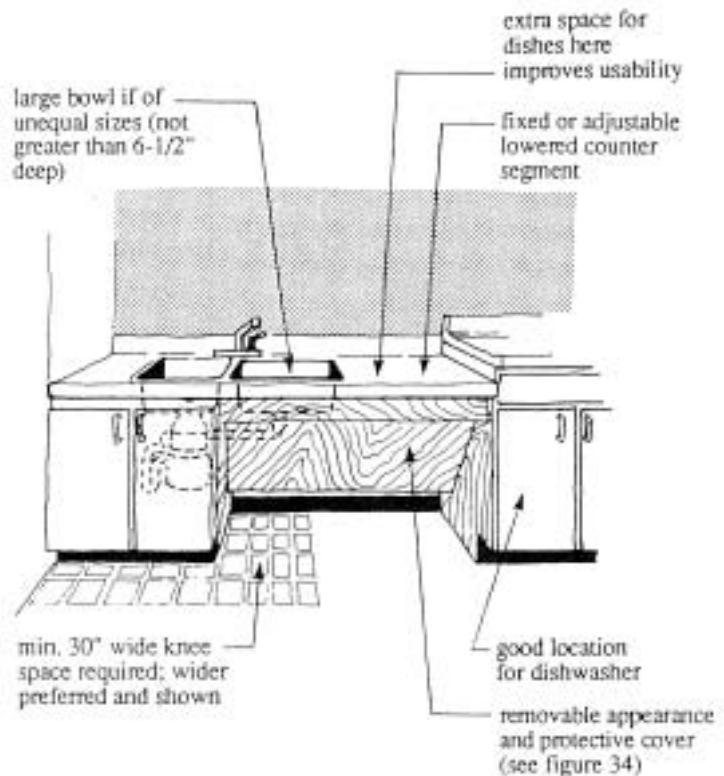


Figure 35.  
A Suggested Garbage Disposal Enclosure

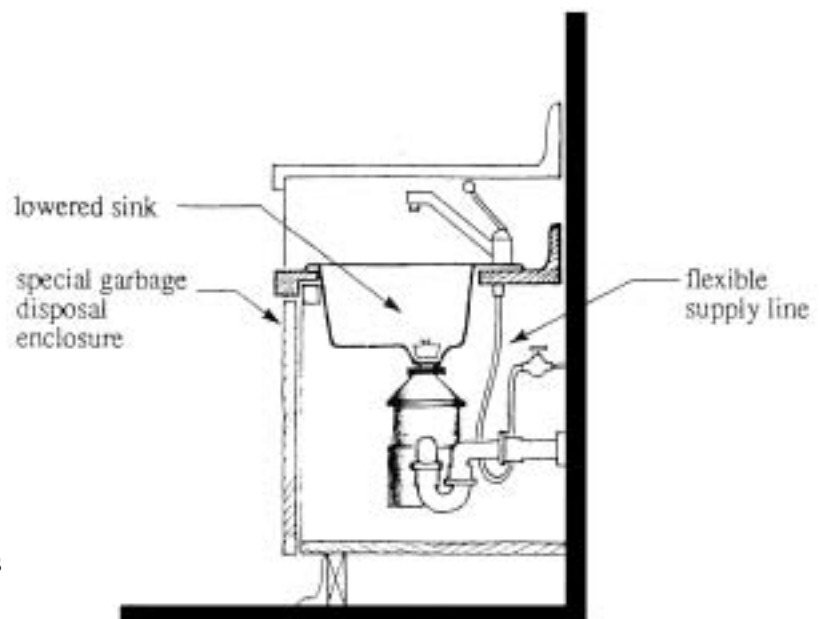
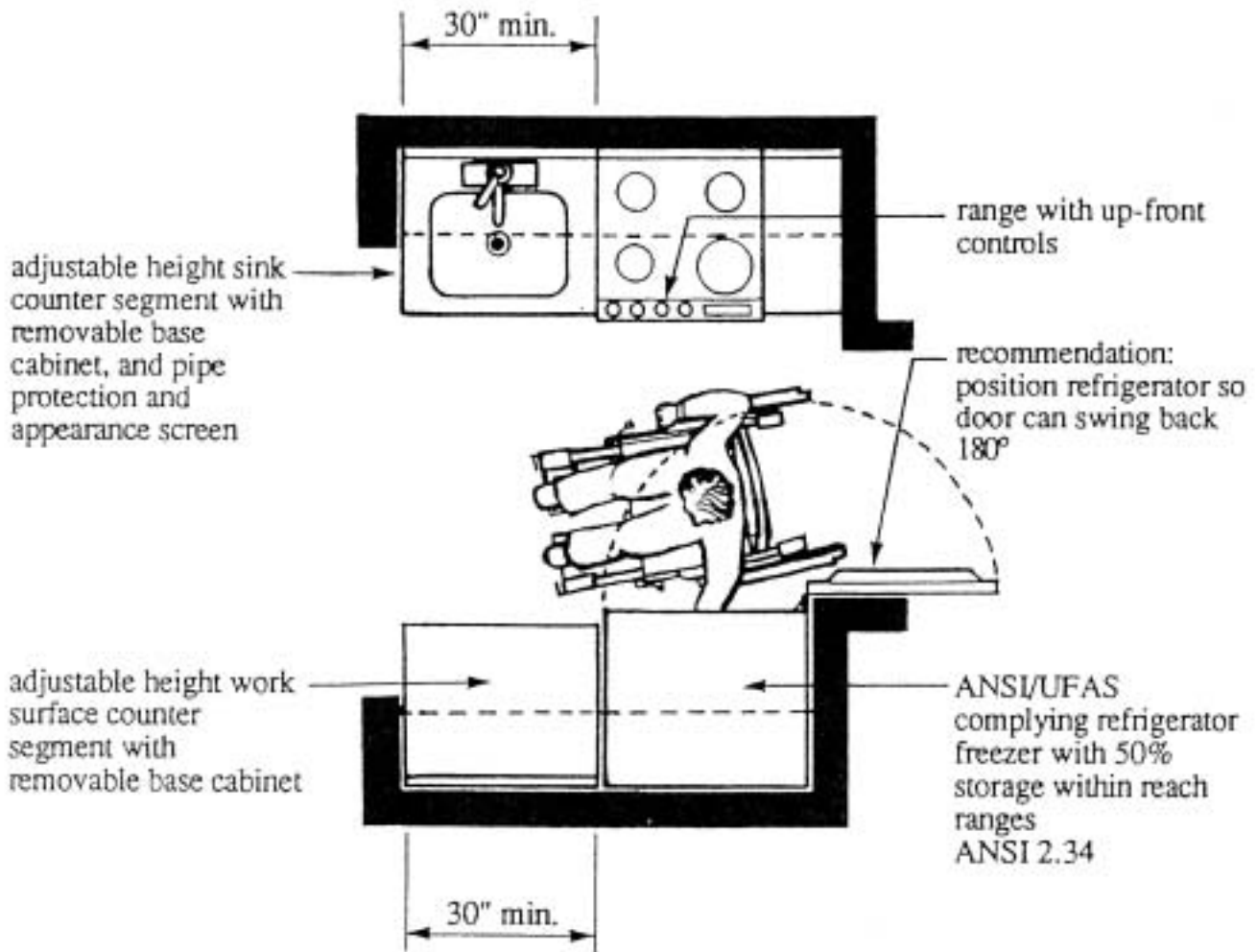


Figure 36.  
Section at Special Garbage Disposal Enclosure

## An Example of a Minimum Size ANSI/UFAS Adaptable Kitchen

The small kitchen shown in Figure 37 is just one example of a minimum sized adaptable kitchen with basic features that meets the standards. Other arrangements that meet the standards are also possible. This kitchen is wheelchair accessible, but it maybe inadequate for many disabled or non-disabled people because of its small size. Consider a kitchen of this type only when a larger kitchen is impossible as in efficiency apartments.

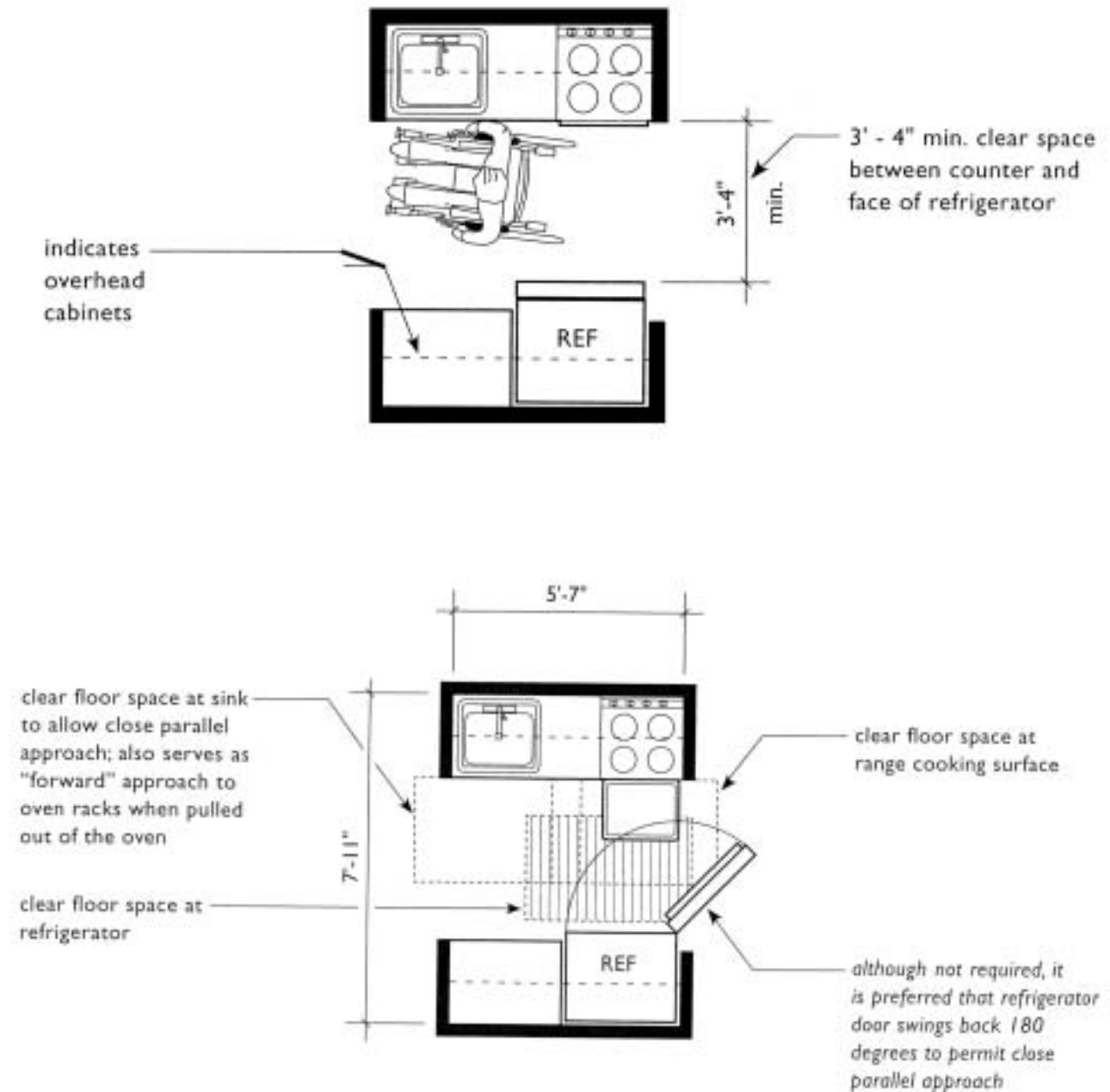


*Figure 37.*  
A Small Kitchen with Adaptable Features  
Plan

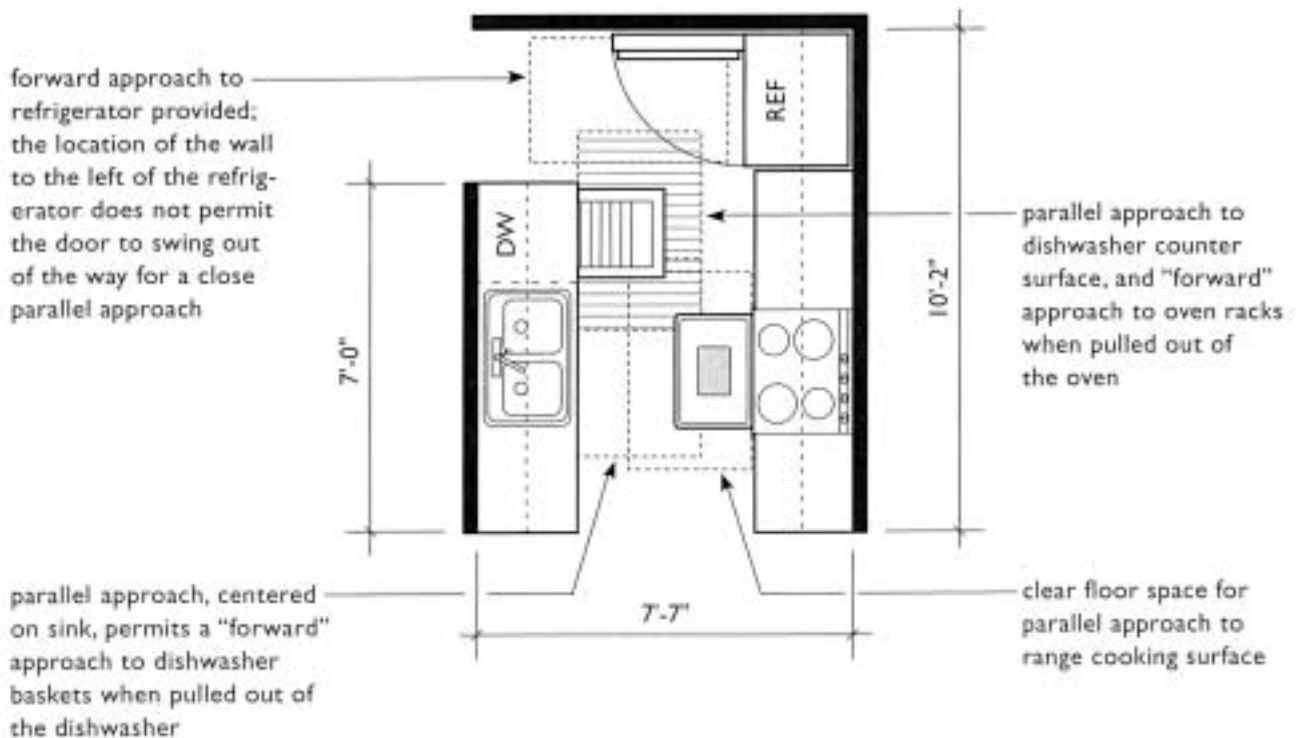
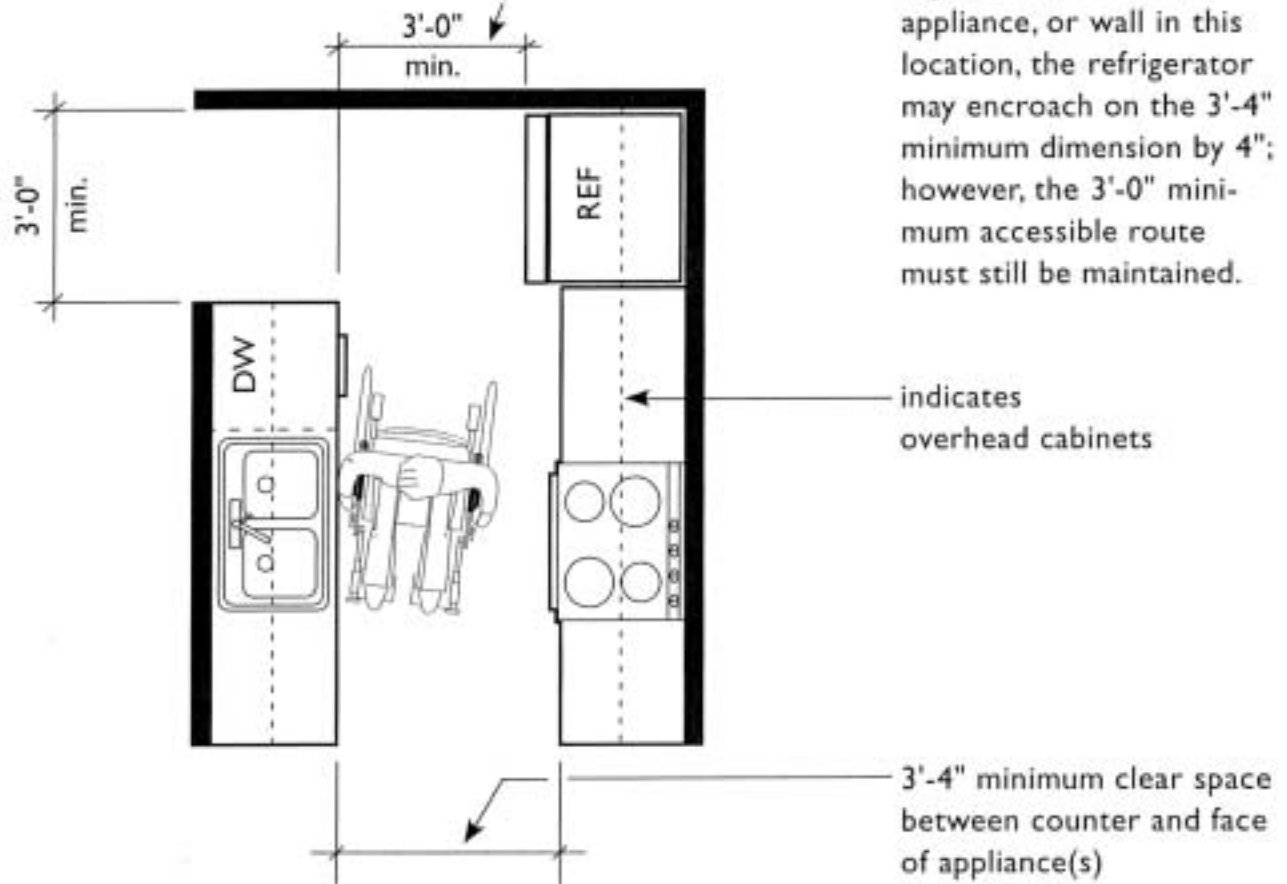
## Very Small Parrallel Wall Kitchen (Without Dishwasher)

In this kitchen design, walls may not continue across either open end because they would obstruct clear floor spaces required at each appliance.

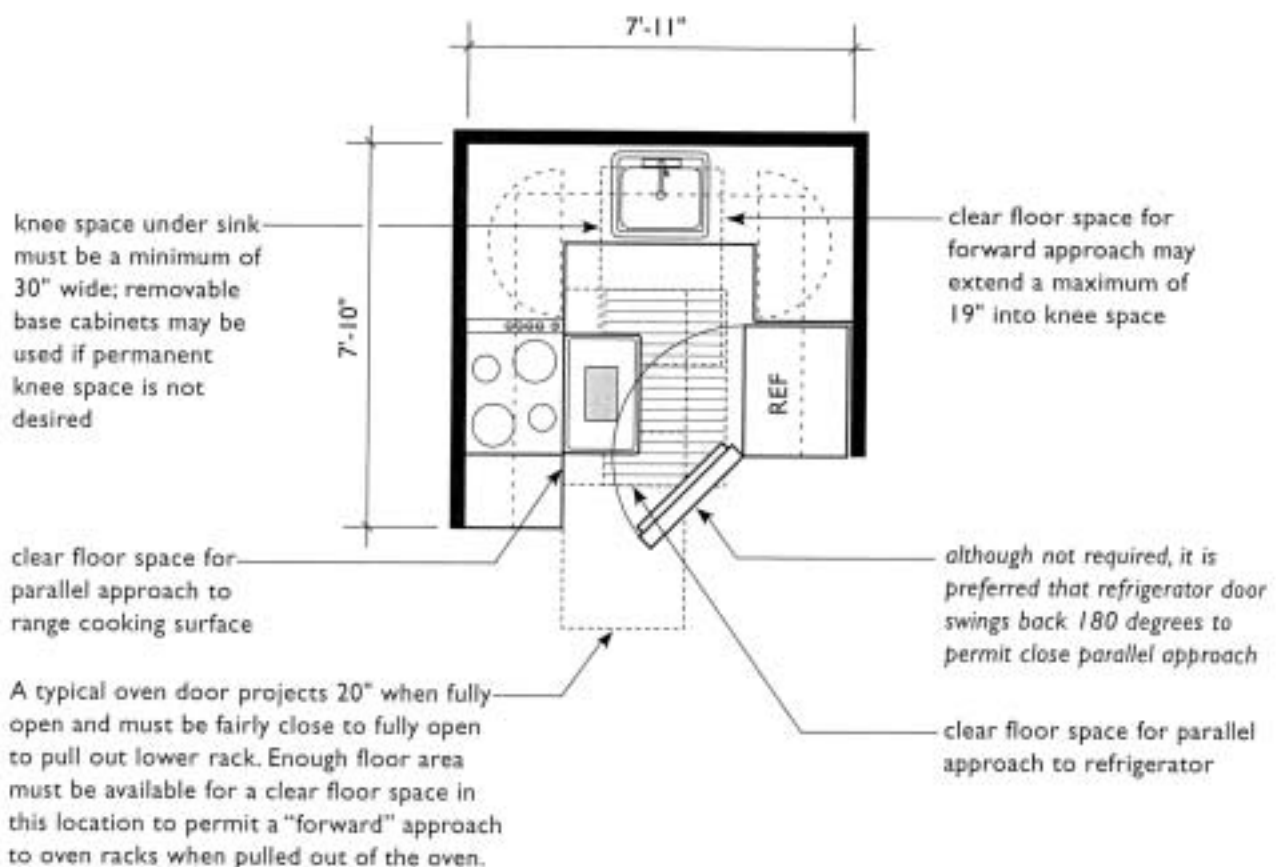
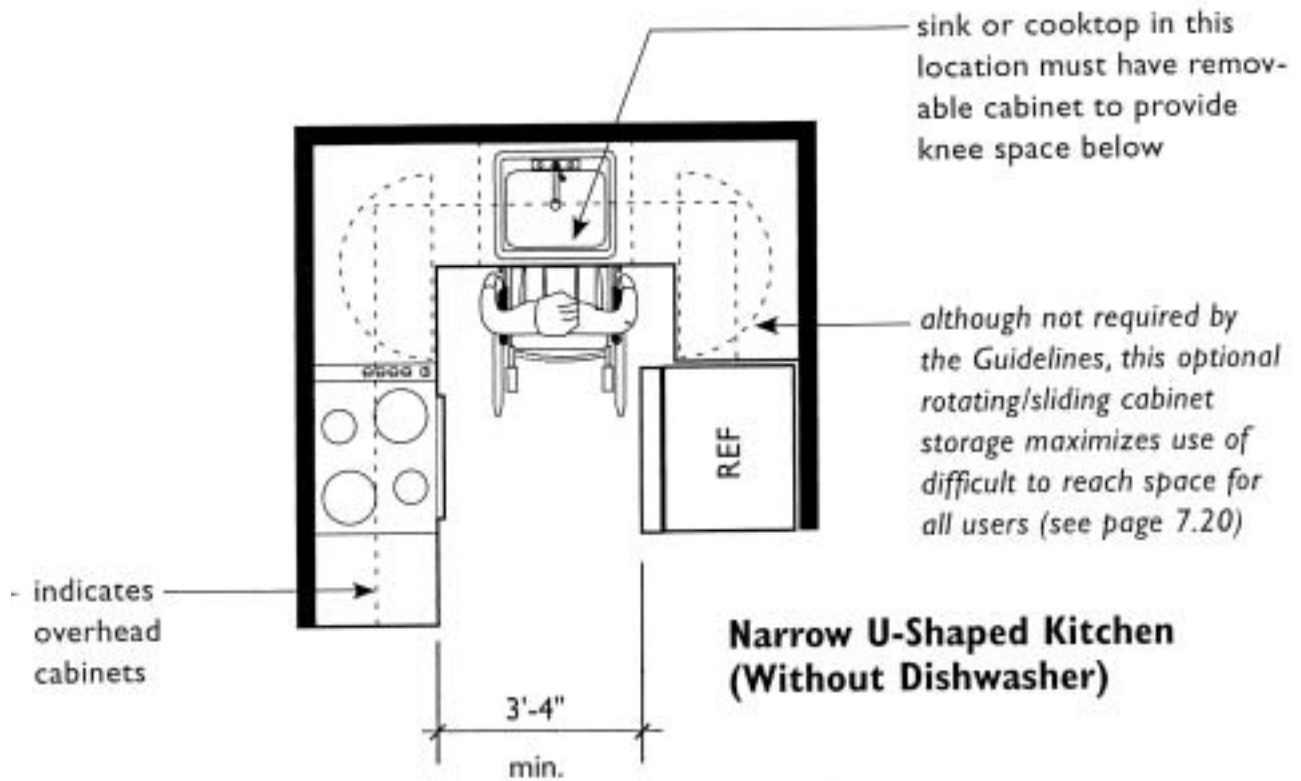
Although discouraged because maneuvering space would be severely restricted, builders can close the sink end, if a removable cabinet under the sink that conceals the knee space is a minimum 30-inches wide; a 36-inch wide knee space is preferred.



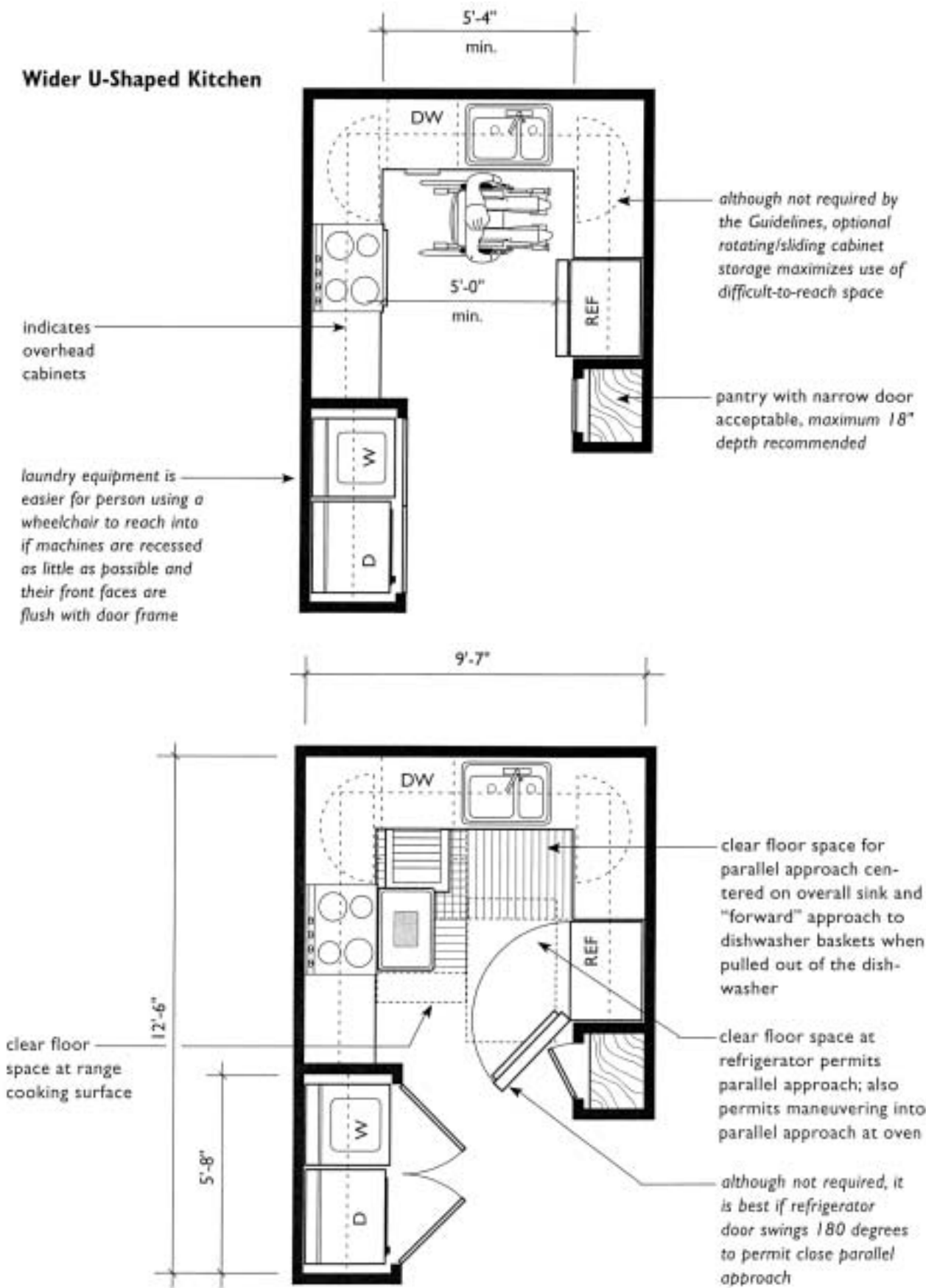
## Parallel Wall Kitchen



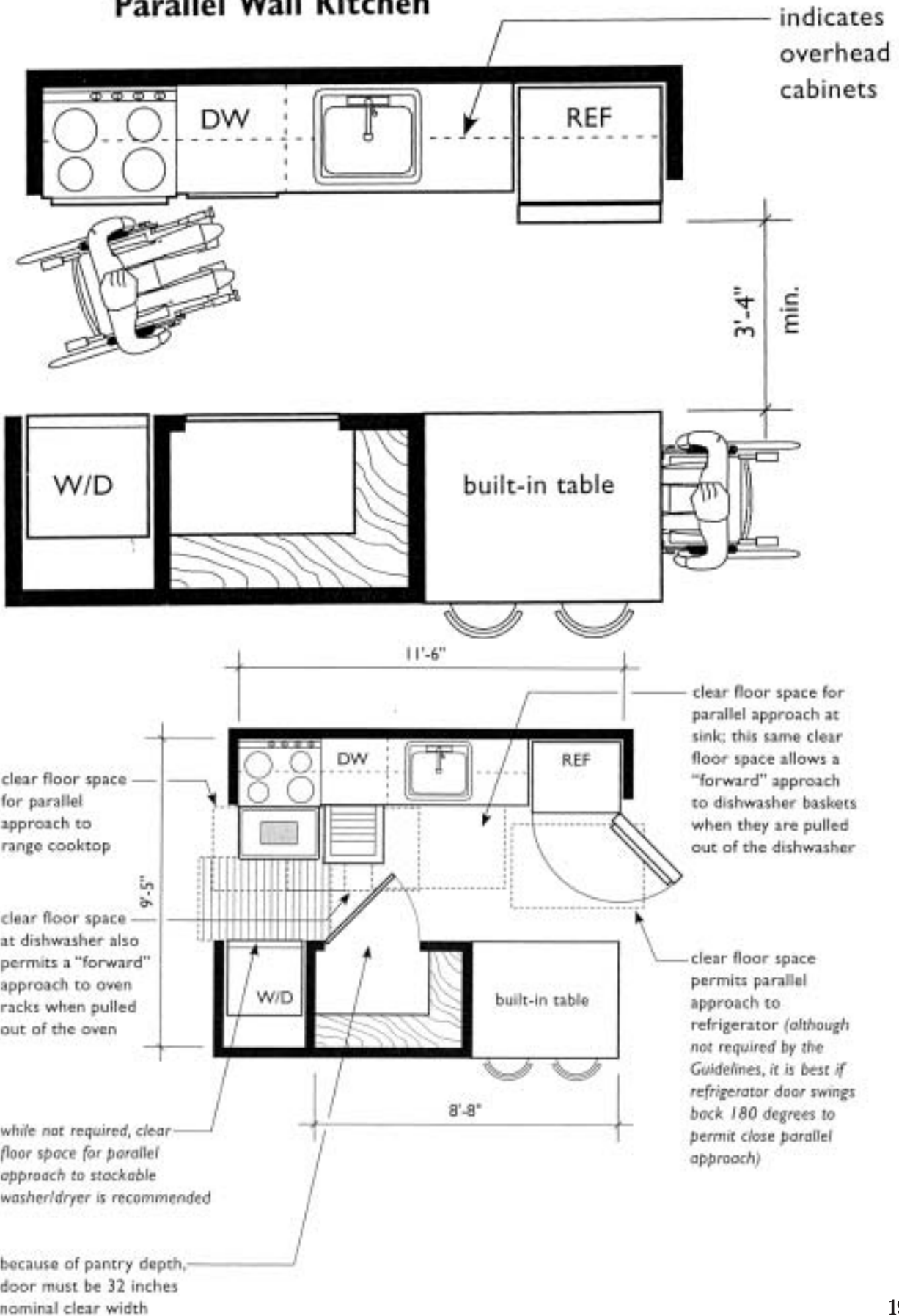




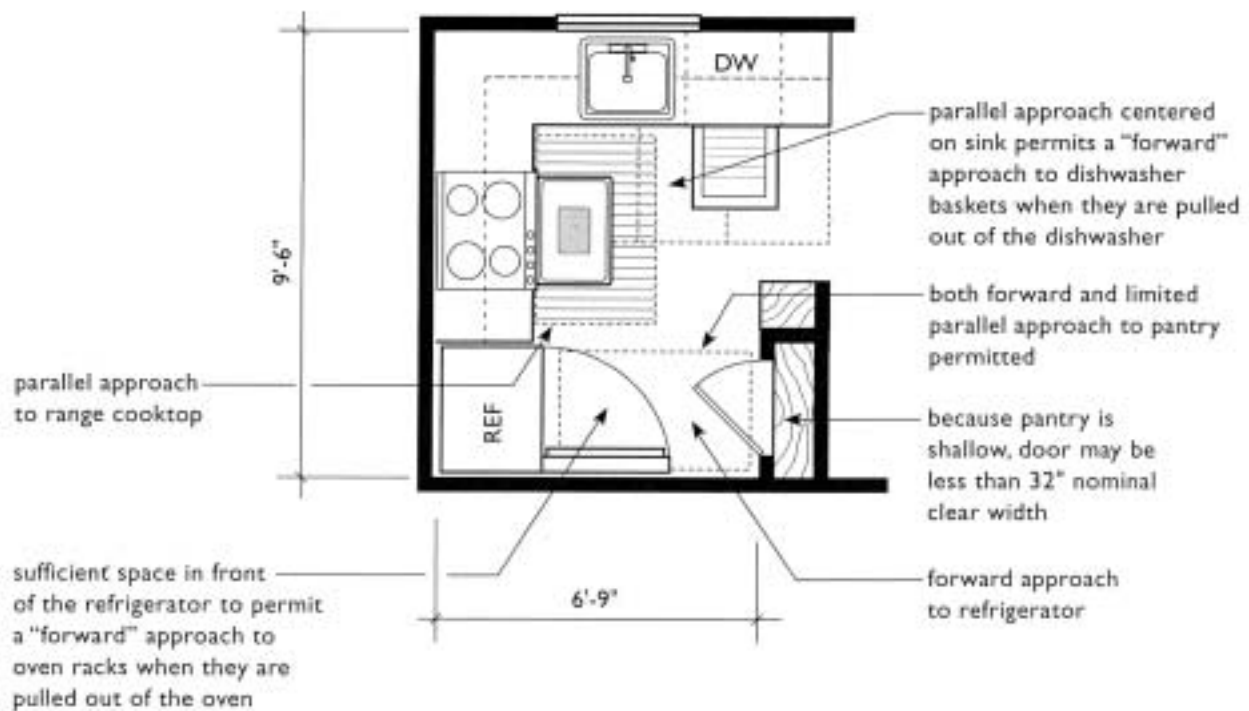
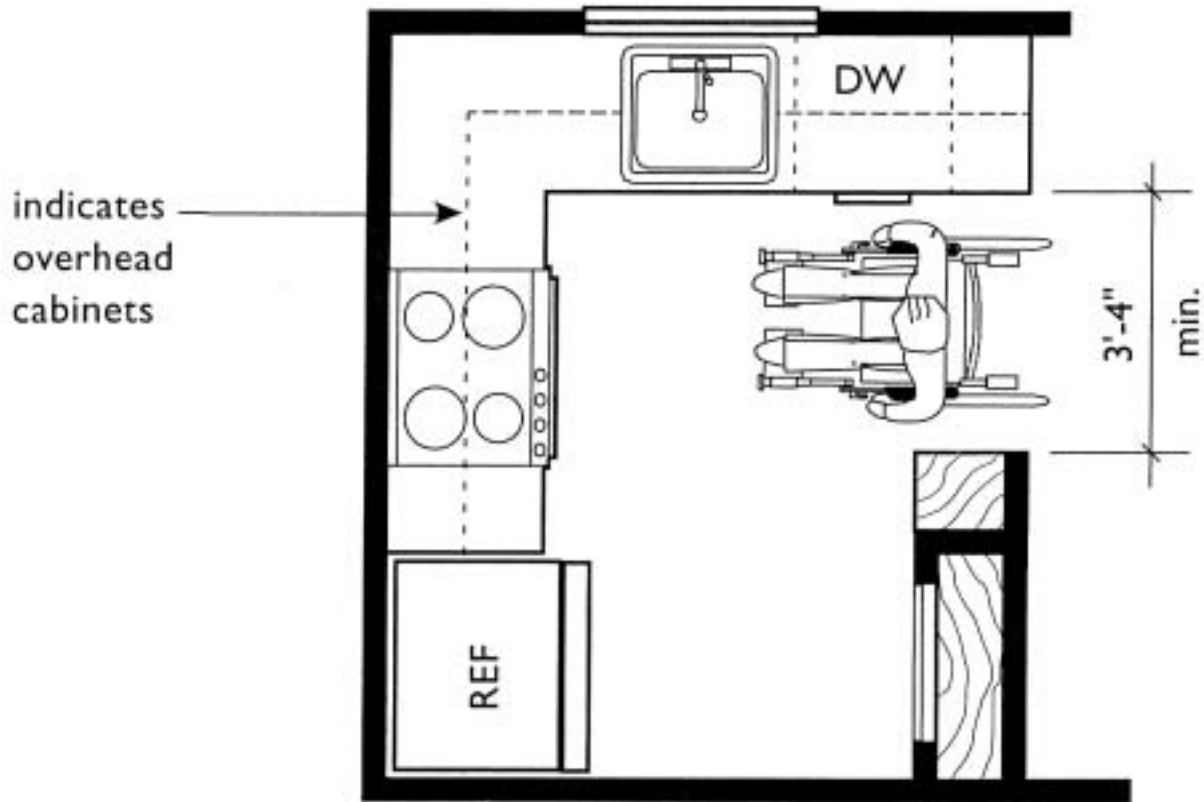
### Wider U-Shaped Kitchen



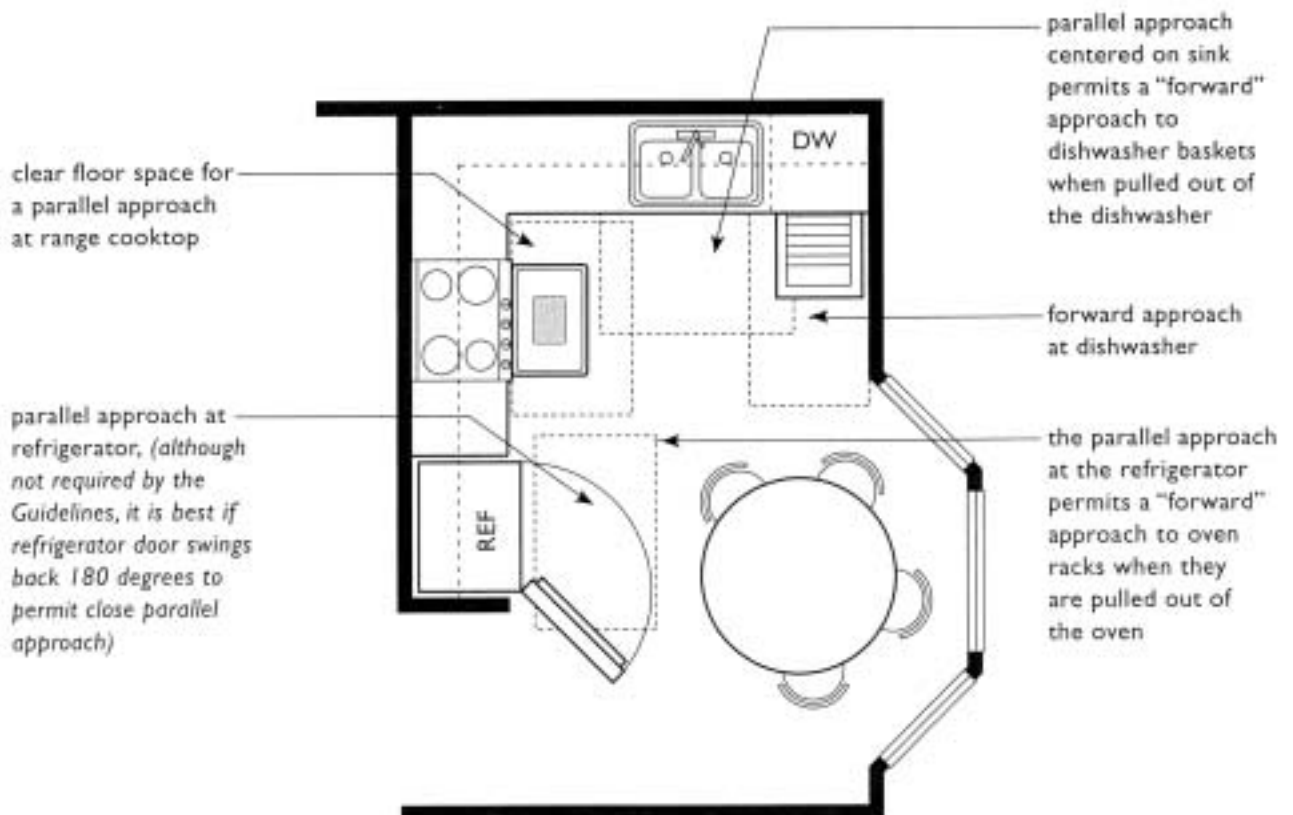
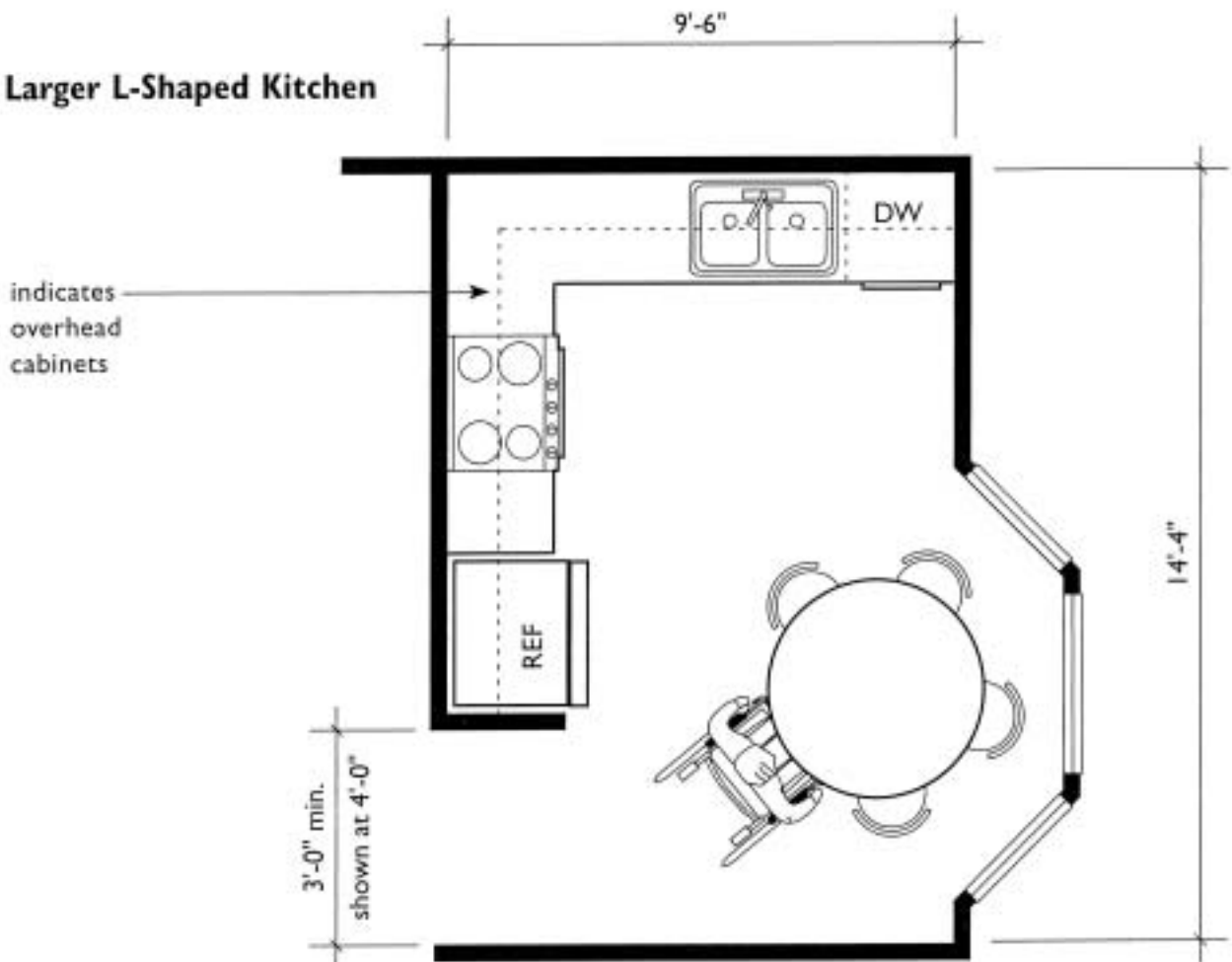
# Parallel Wall Kitchen



## Small L-Shaped Kitchen

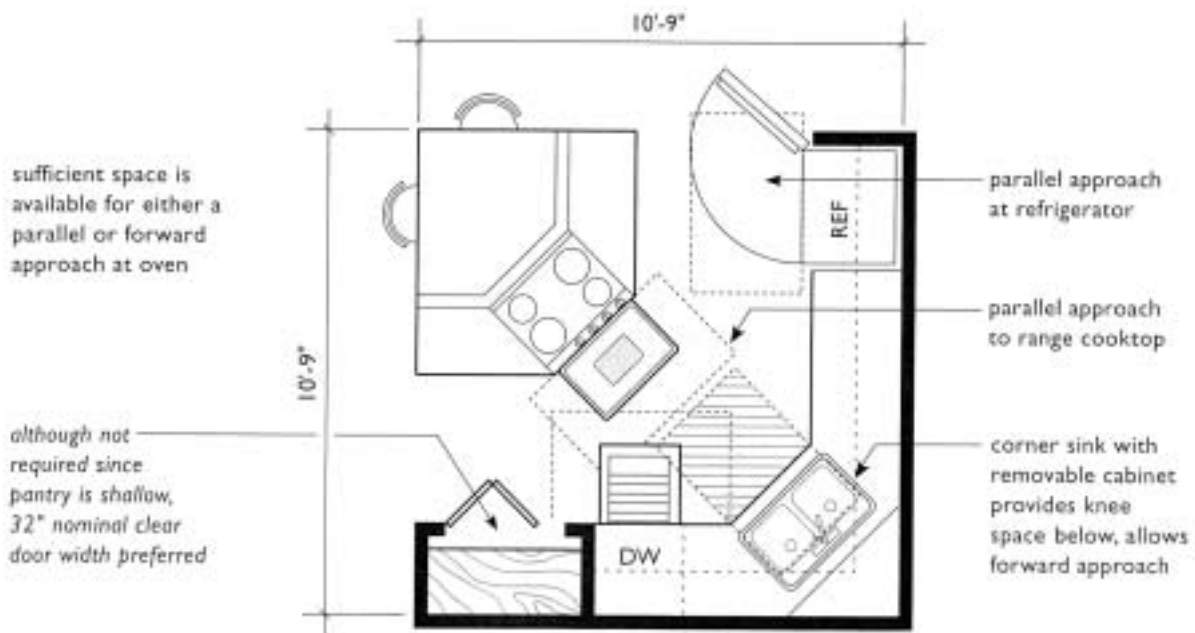
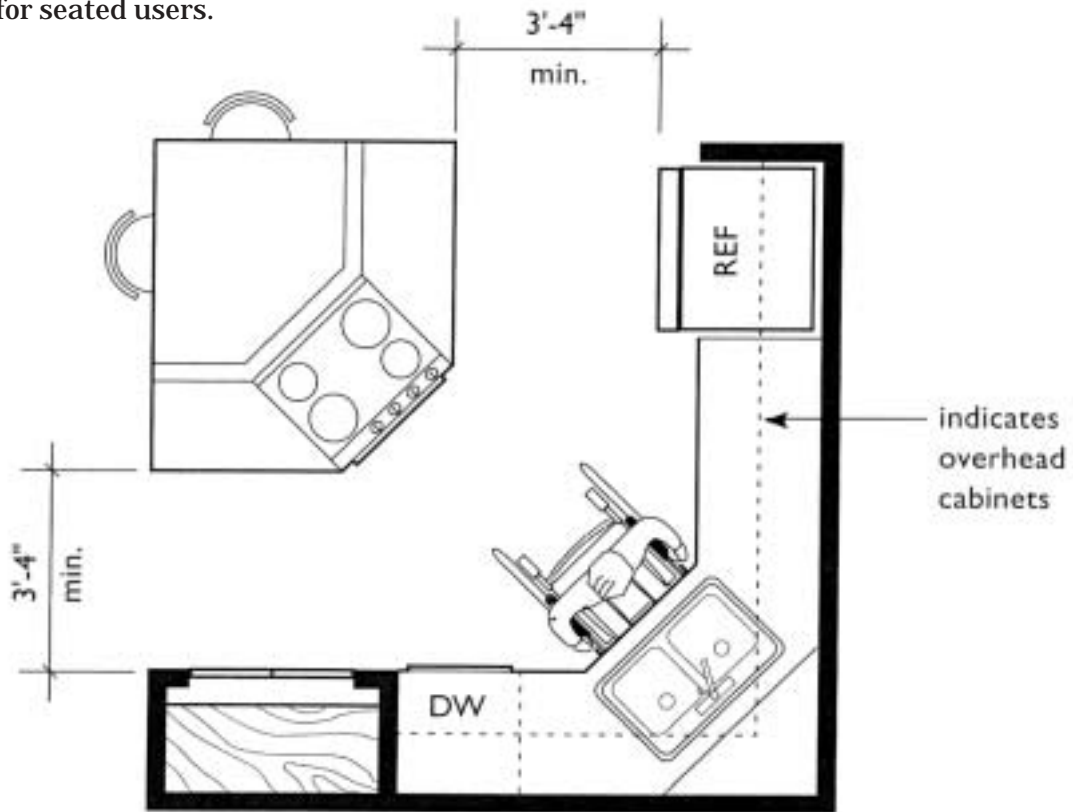


## Larger L-Shaped Kitchen



## Broken U-Shaped Kitchen

If the builder considers a corner position with knee space below for either the sink or the cooktop, it is preferred that the sink be located in the corner, as opposed to the cooktop. This is because a cooktop with knee space below at the standard 36-inch height of a kitchen countertop is dangerous for seated users.



12" to 18" minimum base cabinet recommended so dishwasher is positioned a sufficient distance to allow user to pull in under sink, lower dishwasher door, pull out racks, and load machine

## Spacious U-Shaped Kitchen

While this kitchen has an overall "U" shape, it functions like a parallel wall kitchen with two points of entry and exit and allows close parallel approach to the fixture at the base of the "U".

